

## **EWP® Remote Electric Water Pump Only Instructions**

### **EWP80, Alloy EWP80, EWP115, EWP140, & EWP150**

**PLEASE READ ALL THESE INSTRUCTIONS THOROUGHLY BEFORE YOU START WORK.**

- 1) DO NOT RUN THE PUMP DRY OR YOU WILL DAMAGE THE SEALS**
- 2) DO NOT HARD MOUNT THE PUMP – FIT TO RADIATOR HOSE OR USE PART #8700 MOUNTING BRACKET (sold separately)**

### **EWP® INSTALLATION OPTIONS**

**NOTE:** Before the EWP® is installed it is recommended that the cooling system is properly flushed.

### **INSTALLING AN EWP® AS AN AUXILIARY PUMP**

- ⊕ Leaving the mechanical water pump in place, install the EWP® into the bottom radiator hose.
- ⊕ Remove the thermostat and drill two approx. 3mm (1/8") holes in the thermostat plate to allow some coolant circulation. Re-install ensuring that the thermostat housing is clean, and a new gasket is used if required.

### **DISABLING MECHANICAL WATER PUMP**

- ⊕ Leaving the mechanical water pump in place, install the EWP® into the bottom radiator hose and remove the manufacturer's thermostat.
- ⊕ You will need to bypass the water pump pulley by installing an appropriate length belt. This method makes for an easy installation.
- ⊕ If running the pump continuously remove the thermostat and drill two approx. 3mm (1/8") holes in the thermostat plate to allow some coolant circulation. Re-install ensuring that the thermostat housing is clean, and a new gasket is used if required.
- ⊕ In both these cases, the EWP will pump past the impeller of the mechanical water pump.

**In most cases the weight of the EWP® will be adequately supported by the radiator hose. Where mounting is required, the EWP® must be soft mounted to protect against vibration. For the EWP115, EWP130 and EWP150 Part #8700 Mounting bracket is recommended.**

### **DISENGAGED MECHANICAL WATER PUMP (RECOMMENDED)**

**Note: recommended when using the LCD EWP® & Fan Digital Controller**

- ⊕ Remove the mechanical water pump.
- ⊕ Then remove the impeller from the mechanical pump shaft. Retain the mechanical water pump using the pump pulley as an idler to avoid re-routing the drive belt.
- ⊕ Block any bypass passages and re-install the disengaged water pump ensuring that all gasket surfaces are clean, and the new gaskets are properly fitted to prevent leaks.
- ⊕ Install the EWP® into the bottom radiator hose and remove the thermostat.

### **REMOVED MECHANICAL WATER PUMP (IDEAL)**

**Note: recommended when using the LCD EWP® & Fan Digital Controller**

- ⊕ Remove the mechanical water pump and thermostat from the engine.
- ⊕ Install a Davies Craig EWP Block Adapter or blanking plate (not supplied). Ensuring the gasket surfaces are clean and the appropriate gasket or sealant is used to prevent leaks.
- ⊕ Install the EWP® into the bottom radiator hose. This method may require you to modify or replace the standard radiator hose.
- ⊕ Install an appropriate length belt (not supplied) to drive the accessories.

## EWP® PREFERRED ORIENTATION

**Note: The EWP® is not a self-priming water pump.**

The EWP can be installed in any orientation once it is completely bled of air. The preferred orientation will assist with bleeding the pump and preventing air becoming trapped in the pump.

### FOR THE EWP80 AND ALLOY EWP80

- ⊕ Avoid installing the EWP80 with the Inlet pointing vertically downward, where air can be trapped in the seal chamber.
- ⊕ The preferred orientation for the EWP80 is with the inlet horizontal or on an upward angle with the outlet at the highest point.
  - This orientation is a temporary requirement for the purpose of bleeding the pump and ensuring there is no air trapped within the pump housing. The pump can be set-up in another orientation upon completion of the bleeding procedure.

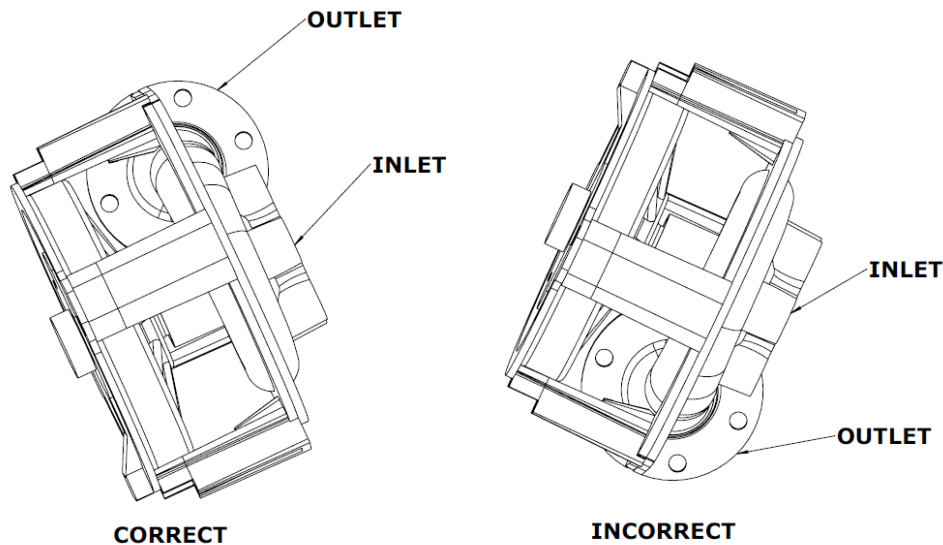

**EWP80 PUMP ORIENTATION DIAGRAM**

### FOR THE EWP115, EWP140 AND EWP150

- ⊕ The preferred orientation for the EWP115, EWP140 and EWP150 is with the inlet horizontal or on a downward angle with the outlet at the highest point.
- ⊕ Avoid installing the EWP115, EWP140 and EWP150 with the Inlet pointing vertically Upwards. In this orientation, air can be trapped in the seal chamber.

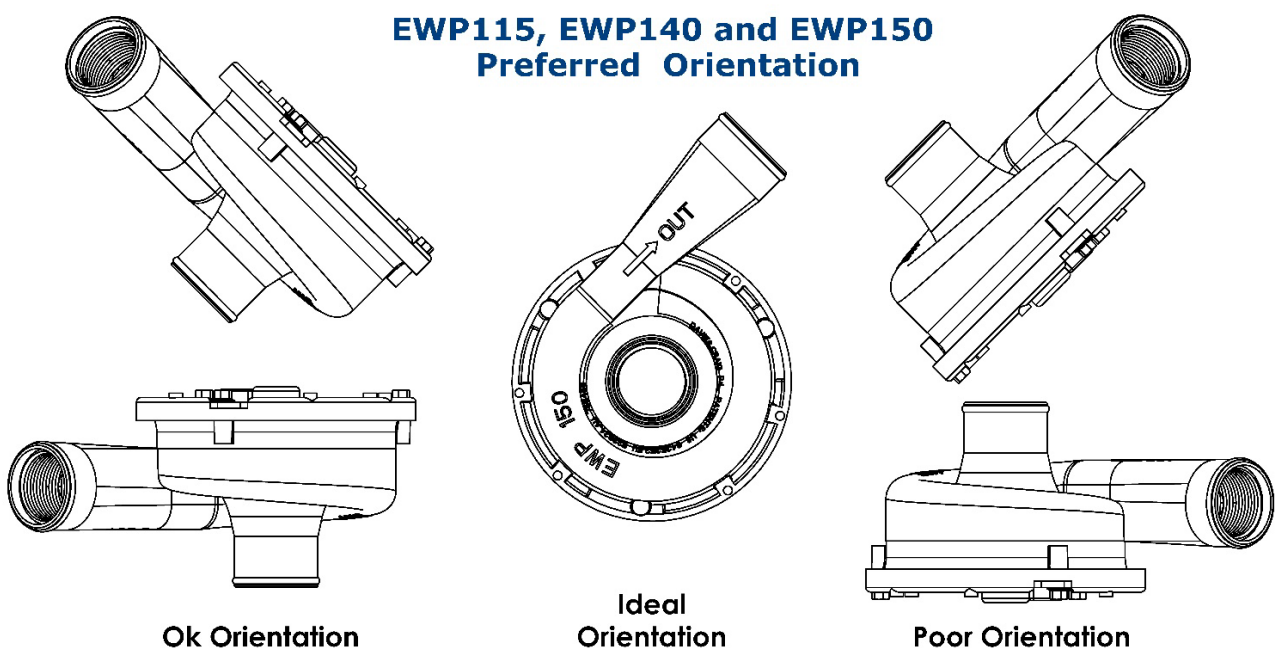

# EWP WIRING

**IMPORTANT: The black wire of the EWP motor must go to earth (negative)**

## Wiring for Continuous Running

- ⊕ Connect **PIN 86 (GREEN)** of your relay (not supplied) the to the ignition.
  - You may use a manual switch or Thematic switch® in the ignition wire.
- ⊕ Connect **PIN 30 (RED)** of your relay to a fused battery positive
- ⊕ Connect **PIN 85** of the relay and the **BLACK** wire from the EWP to earth (negative).
  - You may need to replace or remove the connector on the EWP to match you wiring.
- ⊕ Connect **PIN 87 (BLUE)** of your relay to the positive wire of the EWP.

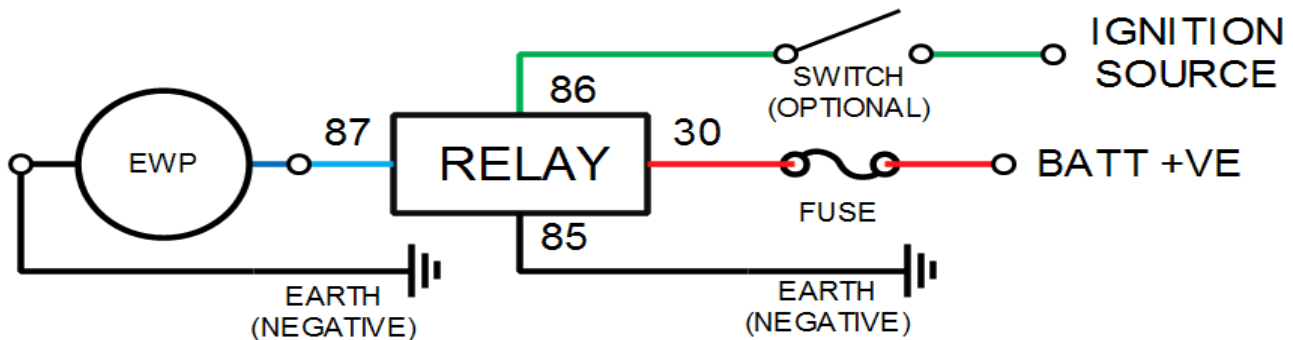

## Wiring with LCD EWP & Fan Digital Controller, #8002 (Recommended)

- ⊕ Install Controller as per instructions and plug the EWP into the "T-connector on the **BLUE** and **BLACK** wire on the controller's loom.

## Wiring for Control by Thematic® switch (Recommended for auxiliary pump applications only)

Davies, Craig has a full range of Thematic® Switches available in both mechanical (#0401, #0404 & #0400) and Digital Thematic® Switches (#0444 & #0500).

- ⊕ Wire the pump as directed by the wiring instructions provided with the Thematic® Switch.
  - All Davies, Craig Thematic® Switches are **ON/OFF**.
  - To allow EWP run on after hot shutdown, wire the Switch direct to the battery.

## IN ALL CASES ONCE EWP INSTALLATION AND WIRING IS COMPLETE

- ⊕ Road test the vehicle and allow the engine to reach normal operating temperature.
- ⊕ Check coolant level again once engine has cooled sufficiently. Top up if required.

## INSTALLATION RECOMMENDATIONS

- ⊕ It is highly recommended the EWP® is operated for at least 5 minutes constant running every month. This will minimise the build-up of any sediment in the EWP® and also lubricate parts within the pump.
- ⊕ For some vehicles, cold climates or when running the EWP continuously you may require the use of a thermostat to help control the coolant temperature. In these cases, you will need to drill 2 x 3mm (1/8") holes in the thermostat plate.
- ⊕ The installation of an EWP® may affect coolant flow through auxiliary coolant loops and the heater core. This change in flow may affect the performance of these loops unless the return line is relocated to the EWP Inlet.
- ⊕ Block the Thermostat bypass passage, to prevent flow from your EWP passing directly back to the radiator without passing through the engine.

These installation instructions will suit most applications but there are circumstances surrounding some engine designs, environments, and the nature of the system involved, which may require other installation arrangements not outlined here. Frequently Asked Questions (FAQ) are listed on our website [www.daviescraig.com.au](http://www.daviescraig.com.au) Emails can be directed to [info@daviescraig.com.au](mailto:info@daviescraig.com.au) or Telephone +61 (0) 3 9369 1234 during business hours.

## OPTIONAL ACCESSORIES (not included)

Thermatic® Switches & EWP® Controller		EWP® Adapters	
#8002	EWP® & Fan Digital Controller	# 8301	Alloy 90° Elbow Flange Adapter: 35mm (1 3/8") Hose Barb
#0500	Digital Gauge Thermatic® Fan/EWP Switch	# 8302	Alloy Flange Adapter: 35mm (1 3/8") Straight Hose Barb
#0444	Digital Thermatic® Switch	# 8303	Alloy 90° Elbow Flange Adapter: 38mm (1 1/2") Hose Barb with Female -16AN ORB
#0400	Thermatic® Switch Combo	# 8304	Alloy Flange Adapter: 38mm (1 1/2") Straight Hose Barb with Female -16AN ORB
#0404	Mechanical Thermatic® Switch & Relay	# 8307	Nylon Flange Adapter: 35mm (1 3/8") Straight Hose Barb
#0401	Mechanical Thermatic® Switch	# 8309	Nylon 90° Elbow Flange Adapter: 35mm (1 3/8") Hose Barb
<b>Switch Accessories</b>		#1024	90° Swivel Elbow Adapter Fitting: -16AN ORB to 38mm (1 1/2") Hose Barb
#0409	Temperature Sensor Adapter Kit	#1025	Alloy Flange Adapter: Male -16AN
#0418	Compression Fitting 1/4" NPT	#1026	Alloy Flange Adapter: Male -20AN
#0465	1/4" NPT Thermal Sensor Upgrade Kit Suits Digital Thermatic® Switches #0444 & #0500	#1027	Alloy Flange Adapter: 25mm (1") Straight Hose Barb
#18415	Coolant Temperature Sensor - (1/4 NPT)	#1028	Alloy Flange Adapter: 19mm (3/4") Straight Hose Barb
<b>EWP® Accessories</b>		#10414	35mm (1 3/8") In-line Adapter no hole
#0415	Air Bleed Adapter Kit	#10415	35mm (1 3/8") In-line Adapter 1/4 NPT Threaded hole
#8700	EWP® Mounting bracket	#18510	3mm (1/8") Rubber Sleeves Adapter
#8520	12V EWP Relay Wiring Kit	#18511	6mm (1/4") Rubber Sleeves Adapter
#8521	24V EWP Relay Wiring Kit	#8315	EWP® Heater Return Adapter Kit

## WARNINGS

- ⊕ **Do not operate your EWP® dry as seal damage may occur, and your warranty may be jeopardised.**
- ⊕ **Waterless coolants increase the load on an EWP® and may reduce pump life.**
- ⊕ **Do not use 'stop leak' or similar leak or crack repair additives as pump damage may occur and your warranty will be jeopardised.**
- ⊕ **The EWP® must be always completely full of coolant to achieve the life and performance expectations of your EWP®.**
- ⊕ **The EWP® impeller tip clearance has been designed to achieve maximum efficiency and is therefore very close to the housing. When new and bedding in, the impeller may touch the internal wall of the EWP® housing causing a slight noise. This sound will cease within a very short time after the impeller has bedded in.**
- ⊕ **The installation of an EWP® may affect coolant flow through auxiliary coolant loops. This change in flow may affect the performance of auxiliary systems like the heater, LPG converter and Turbo cooling. In these cases, you may require an Electric Booster Pump (EBP) to provide constant flow to these systems.**
- ⊕ **DO NOT ATTEMPT to tamper with the EWP including loosening or removing any bolts/screws as this will void any warranty. If you suspect there is a fault or defective product please contact Davies, Craig IMMEDIATELY.**

## WARRANTY



Davies, Craig Pty Ltd warrants for a period of three years or 2000 hours continuous running (whichever is the lesser) from the date of purchase. Davies, Craig will carry out, free of cost, any repairs that are reasonably necessary to correct any fault in the operation of your Davies, Craig product provided that such a fault is directly attributable to a defect in the workmanship or materials used in the manufacture of the part(s). This warranty is void if the product is misused, altered, tampered with, or is installed or used in a manner that is inconsistent with Davies, Craig's written recommendations and/or installation instructions. Labour and consequential costs are excluded.

**DAVIES, CRAIG PTY. LTD.**

To make a warranty claim, go to: [daviescraig.com.au/warranty](http://daviescraig.com.au/warranty)