



## EWP® & FAN DIGITAL CONTROLLER (P/NO: 8020) INSTALLATION INSTRUCTIONS

**FOR INSTALLATION OF DAVIES, CRAIG DIGITAL CONTROLLER FOR USE WITH THE EWP® (ELECTRIC WATER PUMP), OR ELECTRIC FAN AND EBP (ELECTRIC BOOSTER PUMP).**

Congratulations on your purchase of the Davies, Craig EWP® & Fan Digital Controller, designed to regulate the operation of the EWP® by varying the pump speed in response to the temperature of the engine and by switching your Thermatic fan on and off.

The EWP® Digital Controller works best with the removal of the engine thermostat. The Controller has a push-button on the control panel which adjusts the target temperature (set point). Generally, higher engine temperatures will give improved fuel efficiency and lower temperatures more power, but it is recommended that engine operational temperatures be checked with the manufacturer. In combination with a Davies, Craig Thermatic Fan®, the temperature of the whole cooling system can be set to the temperature you want. The EWP® & Fan Digital Controller will run the EWP® after ignition shutdown to eliminate heat soak, and cool down the engine evenly.

***PLEASE READ THESE INSTRUCTIONS IN THEIR ENTIRETY BEFORE YOU START WORK.***

**KIT CONTENTS:**

**Refer Figure 1:**

Item No.	Part No.	Description	Qty
1.	8120	EWP Digital Controller Assembly	1
2.	8411	Wiring Harness (Includes 10Amp Fuse)	1
3.	8414	Sensor Assembly	1
4.	0613	Self Tapping Screw	4
5.	0574	Ring Terminal	1
Not Shown	0410	In-Line Adaptor	1
Not Shown	8510	Rubber Sleeves	2
Not Shown	8512	Hose Clamps	2
Not Shown	8920	Installation Instructions	1
Not Shown	8921	Sensor Installation Instructions	1



**Figure 1: EWP® & Fan Digital Controller - Hardware components.**

## INSTALLING THE EWP® & FAN DIGITAL CONTROLLER (Refer Figure 2 below)

**Do not begin the installation of the EWP® & Fan Digital Controller prior to the EWP® being installed. Refer to the EWP® Installation Instructions for details. Note: Discard all wiring except the fuse from the EWP Kit.**

1. The Controller must be fitted inside the passenger compartment. Locate a hole in the firewall (approx. 20mm in diameter) where the harness wiring (including the sensor & pump “T-connector”) will be able to pass through. If a spot of adequate size cannot be located, then as a last resort, wires can be cut and re-joined.
2. Pass the “T-connector of the wiring harness through the firewall into the engine bay and connect to pump.
3. Pass the **black** sensor cable through the firewall and out to the thermostat housing.
4. Connect the wiring harness to the controller and mount the controller (using 2 of the screws provided) in an appropriate position, such as near the fuse box, so that there is access to the temperature adjustment button --- **avoid mounting the controller where it may be exposed to direct sunlight**. Ensure a good earth connection using the self-tapping screw provided. **NOTE:** The earth(ground) lead must be connected to a metal part of the body.
5. An additional screw is provided for mounting the Controller fuse holder where necessary.
6. Connect the **red** wire from the wiring harness to the battery **positive** using the ring terminal provided. Connect the **green** wire from the wiring harness to an ignition source – the wires may be spliced then soldered if necessary. Ensure no wire is exposed, by insulating the join with electrical tape.
7. Make sure ignition is off and insert fuse (10Amp) from **EWP®** pump packaging into fuse holder.
8. Mount ‘Remote Test Light’ in a location, which will be visible. The ‘Test Light’ may be fitted by inserting it through a 4.6mm drilled hole in a plastic area of the interior/dashboard, or simply with adhesive tape. The ‘Remote Test Light’ has pin connections to assist installation. Heat shrink or insulation tape can be applied to these pin connections once the test light is mounted. This will ensure the connection points are insulated and secure.

**NOTE:** In carrying out the wiring procedure, please bear in mind that it is advantageous to minimise voltage drop and this can be achieved by keeping the wiring as short as possible.

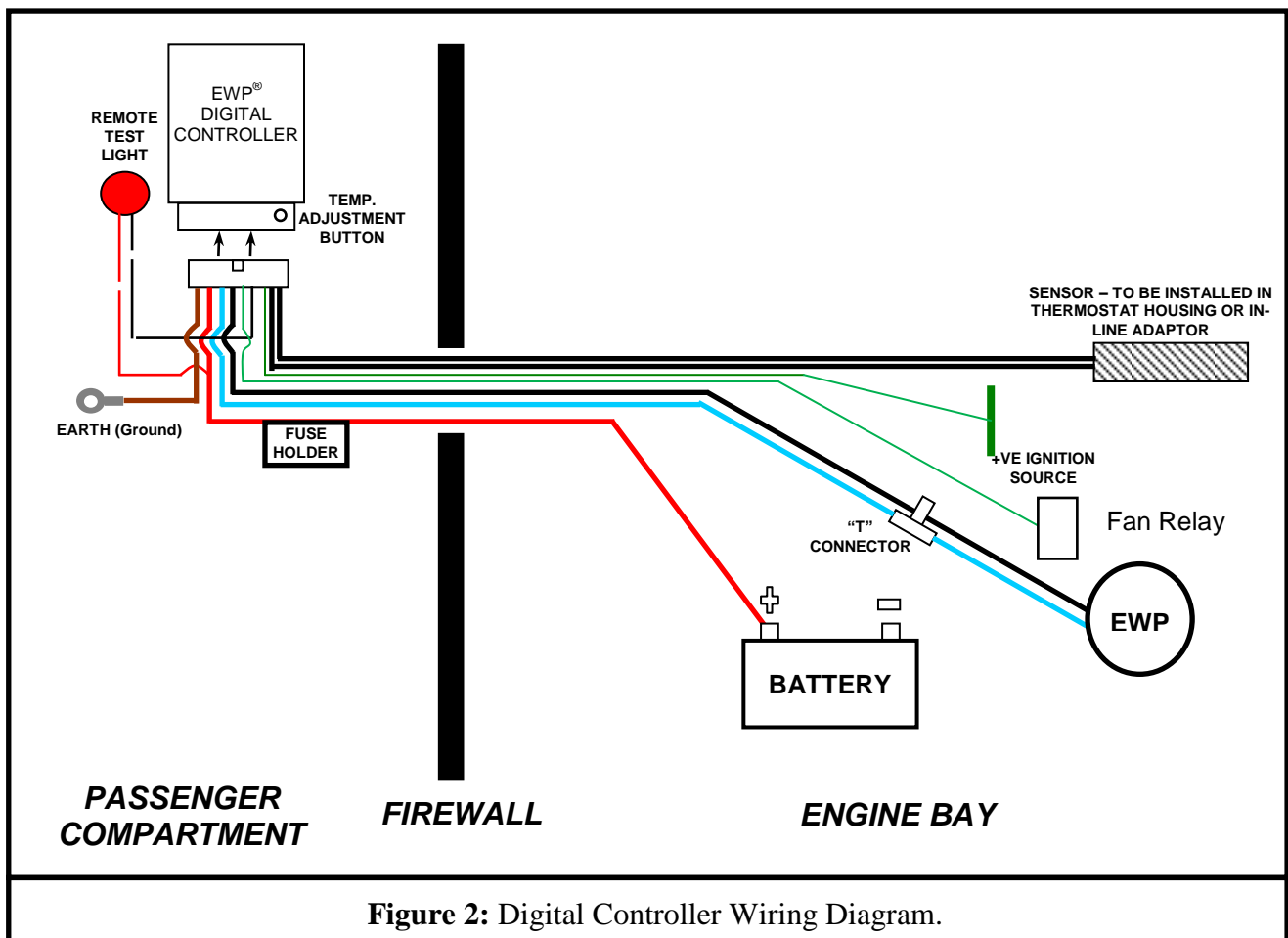

Figure 2: Digital Controller Wiring Diagram.

## INSTALLING EWP® & FAN DIGITAL CONTROLLER SENSOR

There are two installation methods available:

- a) **IN-THERMOSTAT HOUSING METHOD (Refer to separate instruction sheet)**
- b) **IN-LINE ADAPTOR METHOD (Preferred - Refer to separate instruction sheet)**

### **BLEEDING THE COOLING SYSTEM**

1. Fill the cooling system with appropriate coolant.
2. Disconnect the controller 'T' connector from the pump. Using the wiring harness provided in the pump packaging, cut the blue and black wires close to the relay holder, discard the remainder and connect the 'T' connector to the pump. Loosely connect the **blue** wire to the battery **positive** and the **black** to **negative**. With the radiator cap off, run for 5 - 10 minutes to ensure that there is no air trapped in the cooling system. Continue to fill with coolant as the air is removed from the system. Disconnect the wiring from the battery to the pump and discard. Re-connect the pump to the controller 'T' connector. Re-fit the radiator cap before starting the engine.
3. Check hose clamps after a few hours operation of normal temperature and again after 20 hours running. Check for leaks.

## **OPERATION**

### **CONTROLLER**

#### **ALGORITHM-PUMP OPERATION**

Figure 5 shows the typical operational curve of the pump. The 'SET POINT' is the temperature at which full battery/system voltage is supplied to the pump. This can be set to any of the 5 'SET POINTS' available: 75°C, 80°C, 85°C, 90°C, 95°C.

#### **CONTROLLER OPERATION**

##### **LED CHECK:**

Every time ignition is turned ON, all LED's will be on for 5 secs before returning to the normal operation mode. This feature allows for checking that all LED's are operational.

##### **DIAGNOSTICS:**

To avoid any premature diagnostic indication during 'temporary' events – especially where the engine is OFF for very short periods, the diagnostic functions will be activated 2 minutes after ignition is switched ON.

##### **OVER-RUN MODE:**

To eliminate heat-soak after ignition shutdown, the Controller will continue to run the EWP® for 2 minutes or until the temperature has reduced to 5°C below 'set-point' – whichever occurs first. The "Over-Run" feature will eliminate heat soak but will be more effective when used in conjunction with a Thermatic Fan.

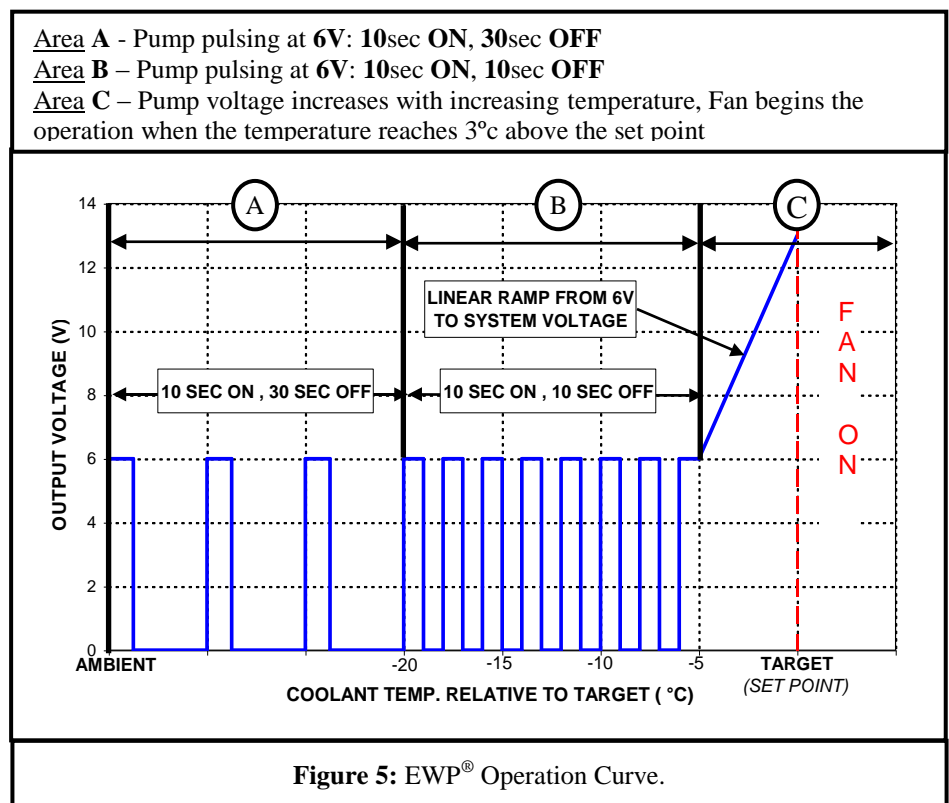

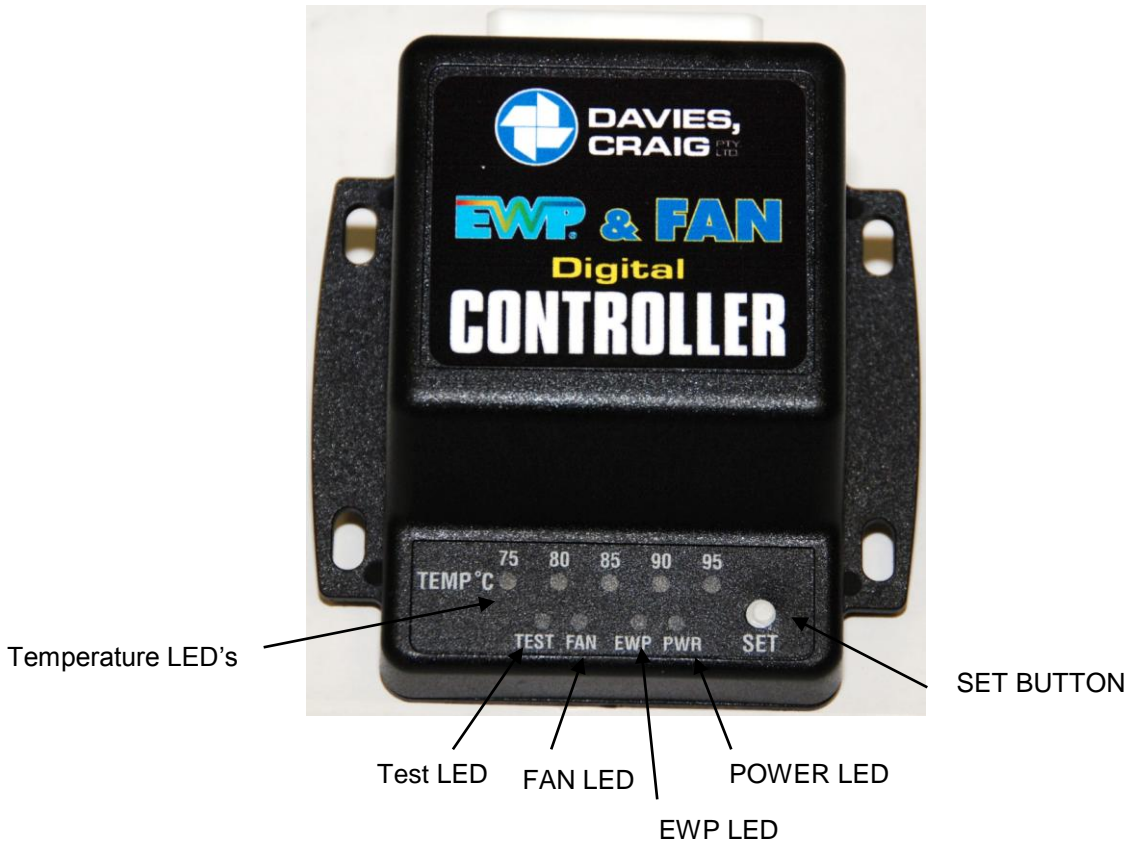

### **LED DISPLAY:**

The following identifies each LED and its operational status:

#### **TEMP LED (GREEN):**

*FLASHING 75°C LED* = Sensor temperature is below 75°C.  
*ON* = ACTUAL sensor temperature.

#### **PWR LED (AMBER):**

*ON* = The controller has power.

#### **EWP LED (GREEN):**

*FLASHING* = EWP operating in ‘pulsing’ mode – Refer Figure 5, areas (A) & (B).  
*ON* = Electric Water Pump (EWP®) running between 6V – Battery Voltage: Refer Figure 5, area (C)

**FAN LED (GREEN):** *ON*= Fan operating

#### **TEST LED (RED):**

*ON* = System warning has been triggered. Therefore, refer to “Diagnostic Chart” in order to determine possible Cause, and take measures to correct the problem.

#### **REMOTE TEST LIGHT (RED):**

This light will “flash” whenever the TEST LED is on. The purpose of this light is to provide remote indication when the TEST LED has been activated.

#### **OVER-RUN MODE:**

During “Over-Run” mode:

- Actual sensor temperature will be indicated by **GREEN** temperature LED.
- PWR LED will flash
- EWP LED will be solid and pump will run at full battery voltage.
- FAN LED will be solid and Fan will run until temperature below the target temp.

## SETTING THE DIGITAL EWP® & FAN CONTROLLER

The Digital EWP Controller can be set in accordance with your requirements. The factory 'set-point' on the controller is 85°C. This setting can be changed by using the 'set-point' adjustment button on the control panel as follows:

- i. Pushing the 'SET' button once will indicate the present setting with an amber LED.
- ii. When 'SET' button is held down, the 'set-point' settings will be scrolled through. Button should be released when desired 'set-point' is reached.
- iii. The LED will then flash and the setting must be confirmed ('locked in') by holding button down for 2 sec. If setting is not confirmed within 5 sec, controller will revert to previous setting.
- iv. To check 'SET' point, see (i) above.

It is recommended that initially the 'set-point' be set to approximately the mechanical thermostat opening temperature. Use a lower 'set-point' to run the engine colder or a higher 'set-point' to run the engine hotter. Generally, running the engine slightly colder will increase the power and running the engine slightly hotter will improve the fuel efficiency.

To verify 'SET' temperature, run the engine and monitor existing engine temperature gauge.

### CONTROLLER INSTRUCTIONS

For your convenience, brief operating instructions are available on the reverse side of the controller.

### Davies Craig Thermatic Fan Wiring to the Digital Controller

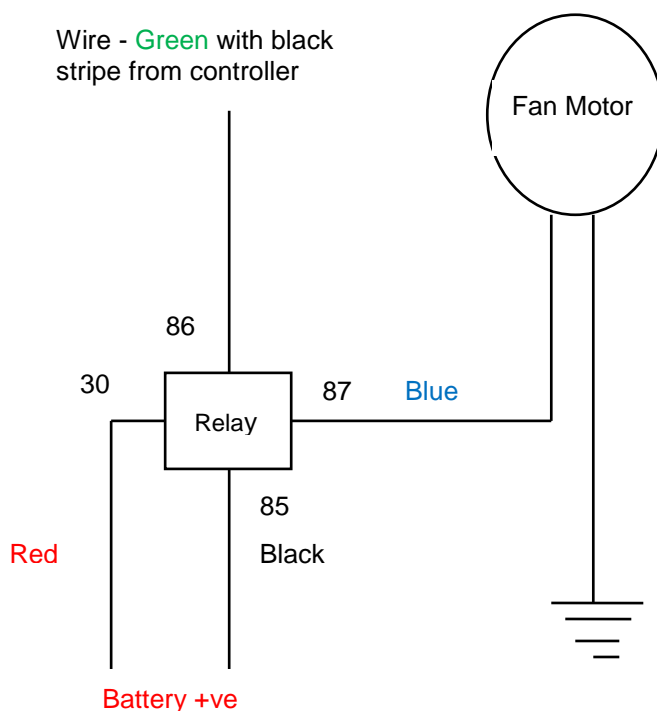

## COOLING SYSTEM DIAGNOSTIC CHART

The following table lists the Digital EWP<sup>®</sup> Controller diagnostic capability for your cooling system and the LED diagnosis sequence.  
**NOTE: In all instances where the TEST light is ON, the EWP is running at full battery voltage.**

	CONDITION	LED SEQUENCE								TROUBLESHOOTING	
		TEST	PWR	EWP	TEMP (75°)	TEMP (80°)	TEMP (85°)	TEMP (90°)	TEMP (95°)		
1	<b>Blown Fuse:</b> Controller does not operate.	OFF	OFF	OFF	OFF	OFF	OFF	OFF	OFF	OFF	Check fuse or connection.
2	<b>Low Voltage:</b> Battery Voltage < 11V.	ON	FLASH	ON	FLASH	ON	ON	ON	ON	ON	Check battery, alternator and/or regulator.
3	<b>High Voltage:</b> Battery Voltage > 15.0V	ON	FLASH	ON	ON	ON	ON	ON	ON	FLASH	Check battery or regulator.
4	<b>Sensor Read Error 1:</b> Open-circuit on sensor lead or thermistor.	ON	ON	ON	FLASH	OFF	OFF	OFF	OFF	OFF	Check sensor wiring.
5	<b>Sensor Read Error 2:</b> Short-circuit of sensor leads.	ON	ON	ON	OFF	OFF	OFF	OFF	OFF	FLASH	Check sensor wiring.
6	<b>Low Operating Temp Fault:</b> Sensor Temp < 30°C after two minutes.	ON	ON	ON	FLASH	ON	ON	ON	ON	ON	Check engine temperature.
7	<b>Over-Temperature:</b> Sensor Temperature is at least 10°C above 'SET' point.	ON	ON	ON	ON	ON	ON	ON	ON	FLASH	Check sensor installation or cooling system. e.g. Fans
8	<b>Set-Point Error:</b> 'SET' point value stored is invalid.	ON	OFF	ON	OFF	OFF	FLASH	OFF	OFF	OFF	Re-set; if this fails contact Davies, Craig.
9	<b>Pump Connection Error:</b> Open circuit on pump leads or pump leads not connected.	ON	ON	FLASH	FLASH	FLASH	FLASH	FLASH	FLASH	FLASH	Check pump wiring and operation.
10	<b>Microprocessor Error:</b> <i>Controller Programme Invalid.</i>	ON	OFF	OFF	OFF	OFF	OFF	OFF	OFF	OFF	Contact Davies, Craig.

**NOTE:** When a temperature related error has occurred, this may not necessarily be associated with the pump but could be associated with the overall cooling system. e.g Fans, fan thermal switch, coolant level. Therefore, inspection should not be limited to the pump alone in trying to isolate the cause

**PLEASE RETAIN THESE INSTRUCTIONS FOR FUTURE REFERENCE**

---

**These installation instructions will suit most situations. However, many conditions of engine design, environment and driving conditions or styles may call for other configurations not described here. Advice is available from Davies, Craig and we would very much appreciate your feedback.**

---

## **CAUTIONS**

- Engine temperature must be monitored closely at all times but especially immediately after installation and until pump operation and capacity have been proved.
- Do not use the vehicle's engine management system or wiring connected to the vehicle's engine management system as an ignition source because it may cause failure of the management system and/or the electrical system. The ignition source must be a steady positive supply of 12-14VDC.

## **INSTALLATION RECOMMENDATIONS**

- For improved heater performance on vehicles which have the heater inlet (return) and outlet ports in the mechanical pump housing, Davies, Craig has developed the Electric Booster Pump, EBP<sup>®</sup>, which fits into the heater hose and boosts flow through the heater circuit and/or cylinder heads. There is more information on our web page [www.daviescraig.com.au](http://www.daviescraig.com.au)
- LPG (Liquid Petroleum Gas) vehicles require constant flow through the LPG converter and if the EWP<sup>®</sup> is used in conjunction with the Controller, we recommend the installation of an EBP<sup>®</sup> (Electric Booster Pump) to overcome freezing of the converter body at start up.

---

## **WARRANTY**

We warrant that for a period of two years or 2000 hours operation (whichever is the lesser) from the date of purchase, we shall carry out, free of cost, any repairs that are reasonably necessary to correct any fault in the operation of your Electric Water Pump Controller provided that such a fault is directly attributable to a defect in the workmanship or materials used in the manufacture of the part(s) and is not due to installation other than described in these instructions. Labour and consequential costs are excluded

If you encounter any difficulties during the installation and require further assistance, please contact Davies, Craig on +61 (0)3 9369-1234.

**DAVIES, CRAIG PTY. LTD.**



## EWP & FAN DIGITAL CONTROLLER P/NO: 8020

### Technical Specifications:

Input Voltage	12V DC to 13.5V DC
Output Voltage	6V to 13.5V
Max. Current	12A
Operating Temperature	-20°C to 60°C (-5°F to 140°F)
Setting Temperatures	75°, 80°, 85°, 90°, 95°C (167°, 176°, 185°, 194°, 203°F)
Fan Cut in Temperature	3°C above the set temperature
Controller Type	PCB with Micro Processor
Sensor Type	Thermistor in waterproof housing
Time Out	2 Min. (or Set -5°C) after ignition OFF
Indicator LED's	Temp., Power ON, Pump mode and Test
Weight	90 grams (3.2 oz.)
Dimensions	101mm (L) X 95mm (W) X 35mm (D) [4" (L) X 3-3/4" (W) X 1-3/8" (D)]