

UNIVERSAL TRANSMISSION/ENGINE OIL COOLER INSTALLATION INSTRUCTIONS

PLEASE READ ALL THESE INSTRUCTIONS THOROUGHLY BEFORE YOU START WORK.
DON'T RUSH - ENSURE YOU HAVE FULL UNDERSTANDING OF THE WORK AHEAD BEFORE YOU COMMENCE. ENSURE YOU HAVE ALL TOOLS AND COMPONENTS REQUIRED.

Cooler Kit Contents:

#602, #605, #610 & #616

- 1 x Universal Oil Cooler
- 1 x Quick fit kit (#602 & #616)

Cooler & Fan Combo Contents:

#600, #608 & #614

- 1 x Universal Oil Cooler
- 1 x 8" 12V Thematic Fan
- 2 x quick fit kit (#602 & #616)
- 1 x quick fit kit (#608)
- 1 x Fan Wiring harness
- 1 x 12V Relay
- Assorted connectors



Oil Cooler Location

When selecting the best location for the oil cooler, always consider a location that will deliver the maximum airflow.

The oil cooler can be mounted in multiple locations on your vehicle.

Position #1 In front of A/C condenser:
75% to 100% efficient

Position #2 Between A/C condenser and radiator:
60% to 75% efficient

Position #3 between radiator and fan:
<60% efficient

Remote Mount

When space in front of the radiator is at a premium. You can remotely mount your oil cooler wherever is most convenient.

For applications and locations where, constant airflow is not always available, the addition of a Thematic fan and Thematic fan switch can help keep temperatures in check.

Note: The Oil Cooler Core will flow in either direction, there is no specified inlet or outlet port.

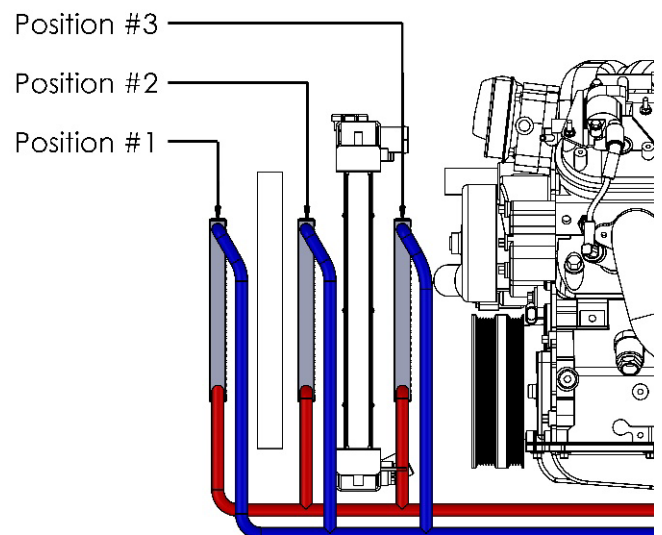

Cooler Orientation

The Cooler Core can be mounted in any orientation. For optimum flow and performance, it is recommended to have the inlet and outlet pointed horizontally, or vertically up.

Note: When oil coolers are fitted, upside-down this can lead to air locks within the system.

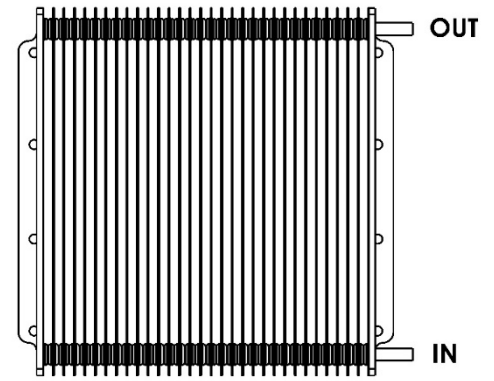
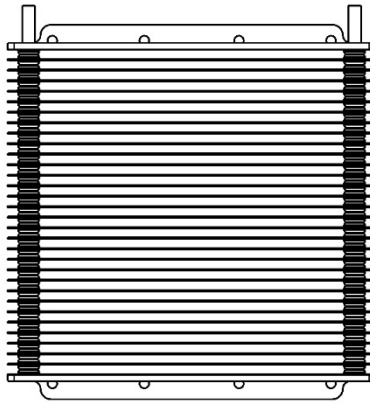

TRANSMISSION OIL COOLER APPLICATIONS

NOTE: To adapt #600/#602/#605/#608/#810 to 3/8" transmission lines Part #1008 AN10 ORB to 3/8 barb fitting (sold separately) can be used.

Auxiliary/Secondary cooling

The best way to ensure your transmission does not overheat is to install an auxiliary (secondary) Transmission Oil Cooler into the Return line from the factory Transmission Oil Cooler.

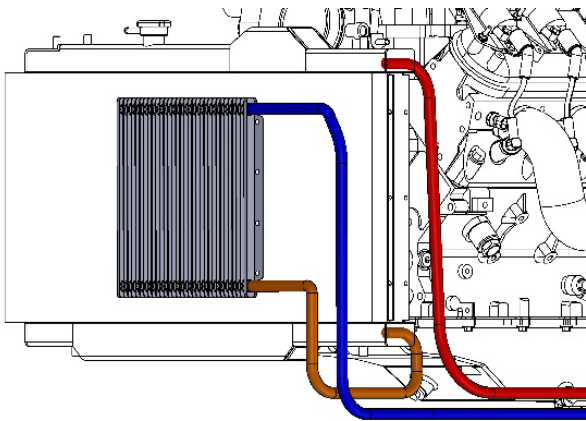

Primary cooling

Installing the Universal Oil Cooler as the primary cooler allows the transmission to have its own cooling system eliminating any unwanted heat transfer between the coolant and transmission fluid.

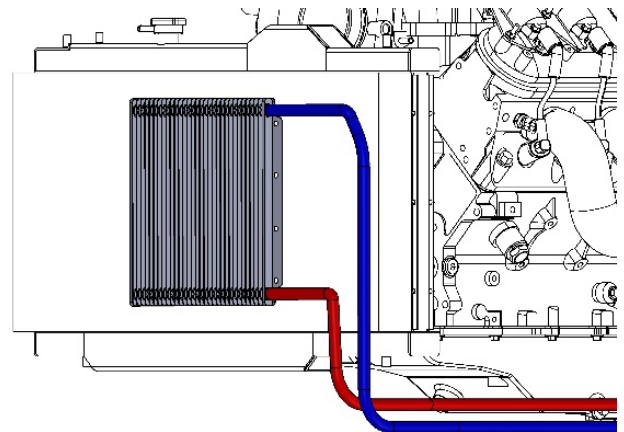

TRANSMISSION OIL LINE IDENTIFICATION

Method 1 – Checking oil line temperature

- Start engine and run until warm. Turn off engine.
- Identify oil return line by feeling both oil lines – the cooler line is the oil return line.

Method 2 – Checking oil flow direction (Requires an observer).

- Place a drip-tray under the transmission oil line and disconnect either line at the radiator.
 - **Caution** – use spanners on both fittings to avoid damage.
- Place a short piece of rubber hose over or into the exposed end of the radiator cooler fitting. Put the rubber hose and the cooler line in the container.
- Start the engine and let it run at idle.
- Determine which line the oil is coming from.
- Stop the engine immediately.
- If the oil came from the radiator during the test, the line disconnected is the return line.

ENGINE OIL COOLER APPLICATION

The best place to tap into the oil supply system is at the oil filter. A Sandwich Plate Adapter or Filter Relocation Kit will be required. (Not available from Davies, Craig)

COOLER MOUNTING

- ⊕ When mounting the Oil Cooler Core to radiator or A/C condenser with the Quick-Fit Kit (Part #0579) supplied, the foam rubber mounting pads should be used.
- ⊕ Remove adhesive backing from the foam rubber pads and position pads on oil cooler mounting flanges. Press pads to ensure each pad sticks firmly to the core.
- ⊕ Place and hold the Oil Cooler Core in designated mounting position with pads facing radiator and/or A/C condenser. Insert the Quick Fit Rod through the centre of the pad at mounting point, push through the radiator and/or A/C condenser fins.
- ⊕ Place locking button over the rod end and push on till foam pad is fully compressed. Cut off excess rod.

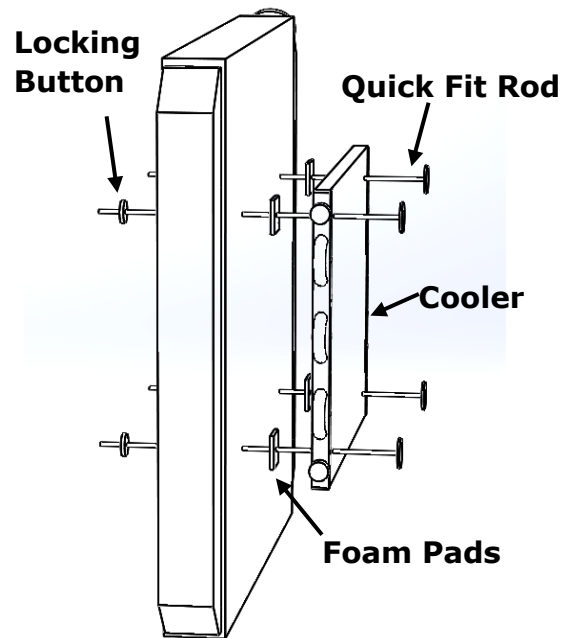

Note: Once the button is pushed onto the rod it can only be removed by cutting the rod.

Note: When Rigid mounting the cooler ensure you don't mount this cooler to the chassis or frame rail that may flex during vehicle operation as this may result in leaks or failure.

INSTALLATION CAUTIONS:

- ⊕ Keep all hoses away from sharp edges, moving parts, wear, and hot points such as exhaust pipes, manifolds, etc. Secure hoses with appropriate nylon ties.
- ⊕ Ensure there are no kinks or tight bends in the hoses. A bend of less than 75mm (3") radius may limit oil flow which may cause transmission failure.
- ⊕ Ideally, the oil cooler should be mounted at least 25mm (1") from fans, 50mm (2") from bonnet, wheel wells and fire wall, and at least 150mm (6") from exhaust manifolds.
- ⊕ When mounting to A/C condenser or radiator core, foam pads must be used as spacers between the oil cooler and condenser/radiator core.
- ⊕ Examine your entire installation carefully after 2 weeks or 200 kilometres to ensure all connections and hoses are secure and totally free of leaks.

8" THERMATIC ELECTRIC FAN INSTALLATION

(Part #600, #608, #614)

Decide which face of the Oil Cooler Core you wish to mount the Thematic Electric Fan. Please pay particular attention to the arrow markings on the fan blade hub regarding the direction the fan should Rotate.

Note: The 8" Fan is assembled to be mounted upstream (pushing), you can change to downstream (Pulling) operation. Please observe the following instructions.

Changing Airflow Direction:

- ⊕ Undo the hex nut, from the centre of the fan blade.
- ⊕ Remove the fan blade from the motor shaft, turn it over and replace. In every case the instruction, printed on the blade, '**This side must face front of vehicle**' and '**this side must face rear of vehicle**' must be followed.
- ⊕ Re-secure the fan blade.
- ⊕ Before mounting the fan to the face of the Cooler Core, note the direction of the arrow on the fan blade. The fan must rotate in the indicated direction.

8" Thermatic Fan Mounting Instructions:

- Take the 4 mounting feet supplied and install them onto the Fan Shroud in the desired locations around the perimeter of the shroud.
- Position the Fan against the oil cooler.
- When mounting the fan to the core with the Quick-Fit Kit (#0579) supplied, be sure the foam rubber mounting pads are used. Remove adhesive backing from the foam pads and position pads as required. Press pads to ensure each pad sticks firmly.
 - To ensure a tight fitting, trim a section off the quick fit rod head to suit.
- When installing the fan to the oil cooler don't use excessive force as this can result in damage to the core.

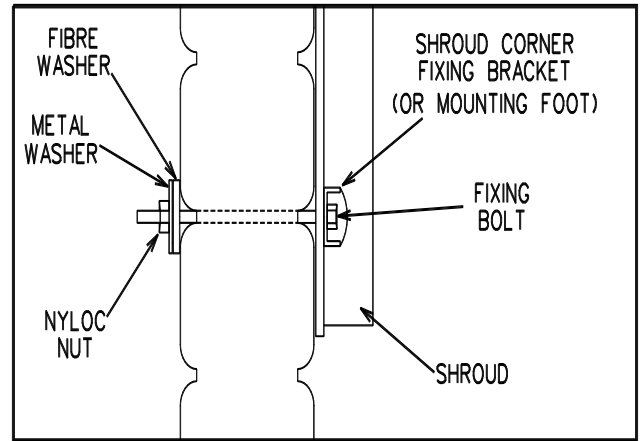

Your Fan MUST rotate in the direction indicated by the arrow and the instruction on the hub of the fan blade "This side must face front of vehicle" must be complied with in all cases.

Wiring Instructions:

It's recommended you disconnect the battery before installing your fan.

Davies, Craig recommends the use of a Thermal Fan Switch to control your Thermatic® Fan. Davies, Craig has a full range of Thermatic® Switches available in both mechanical (#0401, #0404) and Digital Thermatic® Fan Switches (#0444, #0445, #0448, & #0500). (Sold separately)

Transmission fluid detection, use Transmission Temperature Sensor Adapter #1007 – Suits 3/8" Hose

When using a Thermatic® Switch, follow the installation instructions provided with your product.

The wiring diagram below is for basic fan operation. The switch can be a manual or a Thermal Switch.

- Make a temporary connection of the two wires from the motor to power and earth. Run the fan, if it turns in the direction of the arrow, make the connections permanent, if not swap the motor leads and make the connections permanent.

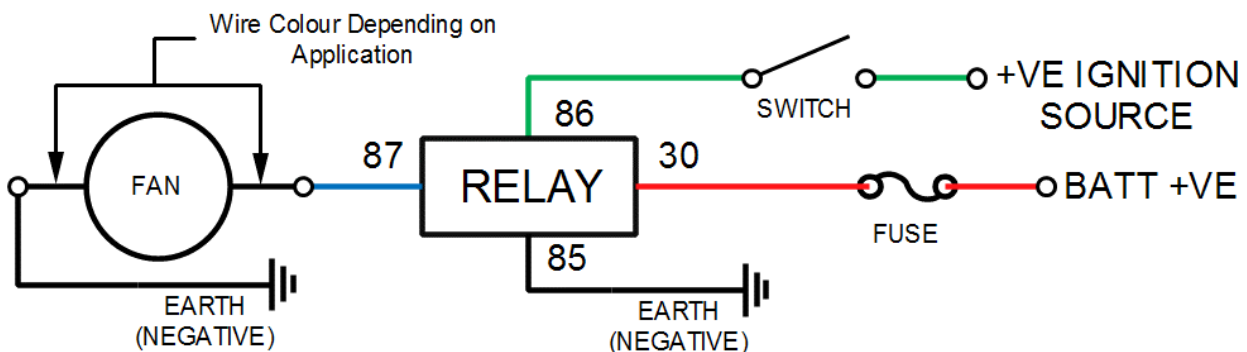

These installation instructions will suit most applications but there are circumstances surrounding some engine designs, environments, and the nature of the system involved, which may require other installation arrangements not outlined here. Frequently Asked Questions (FAQ) are listed on our website www.daviescraig.com.au Emails can be directed to info@daviescraig.com.au or Telephone +61 (0) 3 9369 1234 during business hours.

WARRANTY



Davies, Craig Pty Ltd warrants for a period of three years or 2000 hours continuous running (whichever is the lesser) from the date of purchase. Davies, Craig shall carry out, free of cost, any repairs that are reasonably necessary to correct any fault in the operation of your Davies, Craig product provided that such a fault is directly attributable to a defect in the workmanship or materials used in the manufacture of the part(s). This warranty is void if the product is misused, altered, tampered with, or is installed or used in a manner that is inconsistent with Davies, Craig's written recommendations and/or installation instructions. Labour and consequential costs are excluded. **DAVIES, CRAIG PTY. LTD.**

To make a warranty claim, go to: daviescraig.com.au/warranty